



SPECIFICATION SHEET

BRAND:		Product Photo: 
ORIGIN:	Spain	
SERIES:	Accessories	
PRODUCT DESCRIPTION:	BabyMedi Baby Changing Station *weight: 10kg	
MODEL No.	CP0016H	
FINISH/COLOUR:	White	
DIMENSIONS:	860mm x 570mm x 100mm	
OPTIONAL MATCHING PARTS:		

Technical Informations:

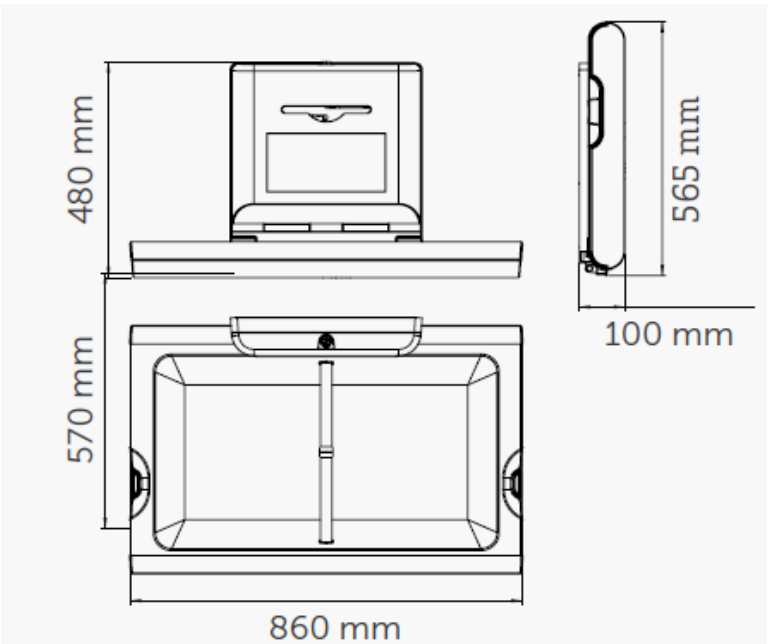

REMINDER:	<p style="color: magenta;">Standard procedure of flushing pipe line must be done before connecting to the faucet/mixer, and filter washer must be installed to avoid blocking of nozzles,. Warranty may void if fail to do</p> <p>Do not use abrasive or aggressive cleaners and or contain chlorine or hydrochloric acid solution for cleaning.</p> <p>All information stated above are solely for reference only, and should be based on the actual submission sample. Dimensions and specifications are subject to change without prior notice.</p>
------------------	--