

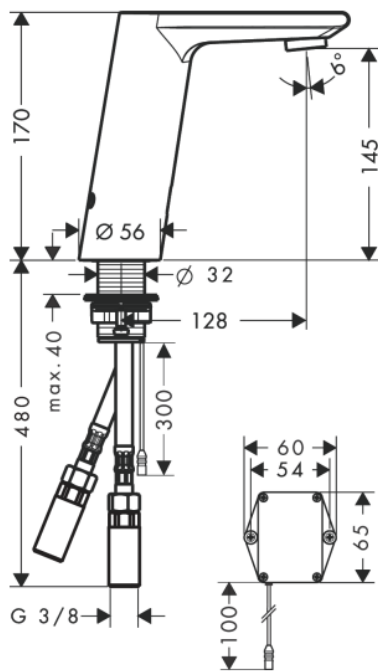

Brand : HANSGROHE, Germany
 Name : Metris S Electronic Basin Mixer with Temperature Pre-adjustment
 Item Code : 31101.000
 Designer : Hansgrohe
 Color / Finish : Chrome
 Dimensions :

Product info

- ComfortZone 150, projection 128 mm
- Flow rate at 3 bar: 5 l/min
- Theft-proof aerator
- Temperature limitation adjustable
- Temperature pre-adjustable
- Non-return valve
- Suitable for continuous flow water heaters
- Infrared sensor technology
- Adjustable optical range of infrared sensor (2 settings)
- Battery condition indicator available 6 V Lithium battery
- Hygiene rinse activatable (automatic water flow for 10 seconds every 24 hours following the last operation)
- Permanent rinse activatable (single water flow for 180 seconds, suitable for thermal disinfection)
- Manual water stop for washbasin cleaning
- Performance may be impaired if the sensor is obscured by the design of the wash basin, or when the wash basin is oversized and the distance between sensor and the wash basin edge is larger than 75 mm
- Functional restriction due to too large distance
- Connection dimension: DN15 · TÜV certified
- Dirt filters in the connection hoses
- Two filter units with fine filter to protect from incoming dirt, for assembly on existing angle valves, filter element can be removed and cleaned



Technology



Flowchart

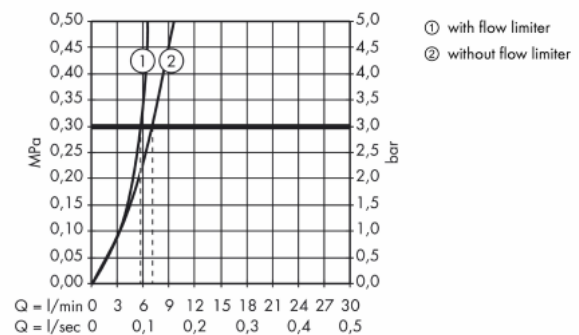

Flushing of pipe must be done before fittings are installed. Failure to do so voids the warranty.

Follow cleaning instructions and avoid using any harmful chemicals.

All information is for reference only. Installation shall always be based on the specs provided with actual delivered items.

For more info, visit www.kuysen.com